

# GT3800 TRUCK SYSTEM



**KAR**  
**GRABBER**<sup>®</sup>  
R.G. GRABBER, INC.

310 Sterling Industrial Road • Brunswick GA 31525 USA

912-264-1804 • 912-264-1844 Fax

[www.grabber.com](http://www.grabber.com)

# GT3800 Truck System

## TABLE OF CONTENTS

Specifications and Dimensions .....3  
Component Inventory and Descriptions ..... 4-7

## OPTIONAL ACCESSORIES

Optional Accessories..... 7-8

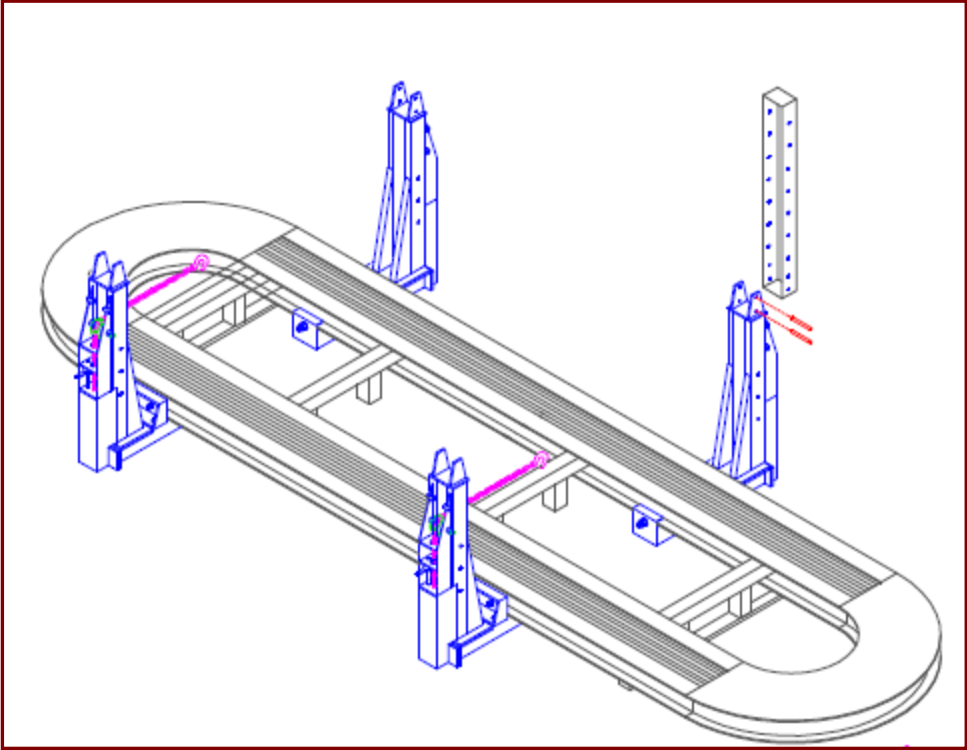

## DIMENSIONAL SPECIFICATIONS

Bed Length.....	38'	11.58m
Ramp Length.....	10'	3.05m
Tower Overhang .....	36"	914mm
Overall Treadway Width .....	36"	914mm
Center Opening Width.....	30"	732mm
Bed Width.....	8' 6"	2.59m
Bed Width (Including Towers) .....	14' 6"	4.42m
Working Height.....	22"	558.8mm
Floor to Top of Tower .....	13' 6"	4.11m
Tower Height.....	12'	3.66m

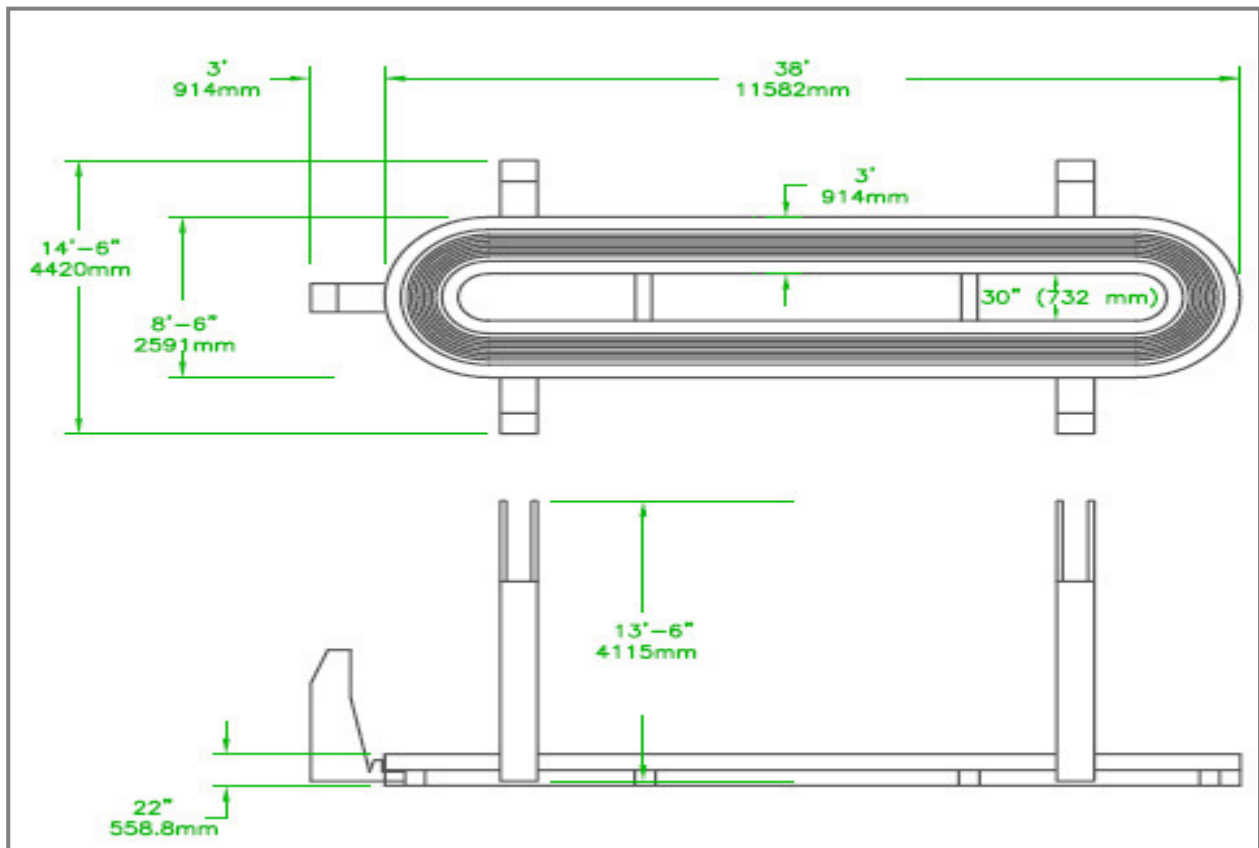

## COMPONENT INVENTORY & DESCRIPTION

### Swivel Pull Towers with 25-Ton RAM

*Catalog #: GT101S      Quantity: 2, 3 or 4 Towers*

Mounted on gliding platforms, each tower can be easily moved into position. (2) Pull towers feature a 4' roof pull extension, remaining towers may be upgraded. All towers feature continuous pull capability, 25-Ton-14" stroke ram and cover for the hydraulics. A dedicated air/hydraulic pump with hose and gauge are also included.

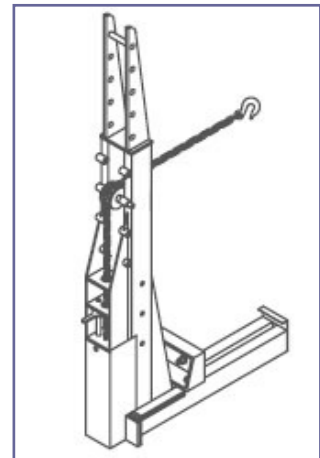

### 25-Ton Lift Stands Hydraulic

*Catalog #: GT103      Quantity: 2*

Air/hydraulic controlled, fully portable and can be placed anywhere that frame support or repair is necessary. A 25-ton-14" (355.60 mm) stroke RAM provides a height range of 26" - 40" (660.40 - 1016.00 mm). Lift stand may be used in conjunction with the floating crossmember and is especially useful for repairing frame twist.

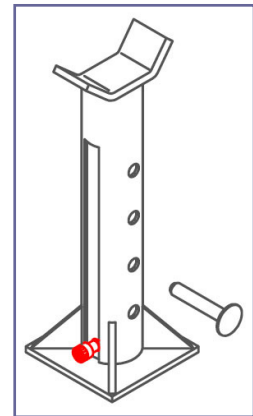

### Down Pull Assembly

*Catalog #: GT105      Quantity: 1*

Clamps around the inside or outside treadway beam. Includes (1) 5/8" (15.88 mm) chain roller and one retainer pin. Inner housing and outer housing mate via the retainer pin and attach to treadway.

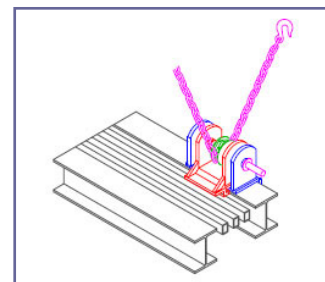

### Chain Slack Remover

*Catalog #: GT108      Quantity: 2*

Removes chain slack to insure a solid tie-down point. Enables the pull tower to maximize its pull efficiency. Prevents the frame from 'skating' across the platform. Chain slack remover may be used at any location on the platform by attaching to edge of rack treadway.

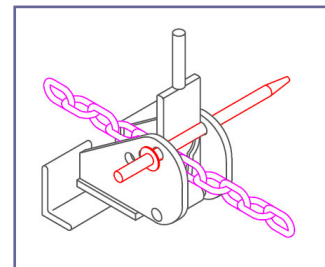

## COMPONENT INVENTORY & DESCRIPTION

### Rail Pull Tool Assembly

Catalog #: GT140 Quantity: 2

Consists of various parts that can be used in different combinations and configurations for pulling twist in rails and correcting upper and lower flange.

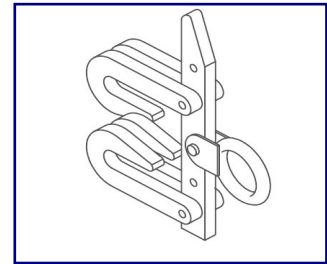

### Heavy Duty Pull Plate

Catalog #: GT142 Quantity: 2

Use as a tie-down or pull tool when repairing a diamond. Attaches to the front or rear of frame rail.

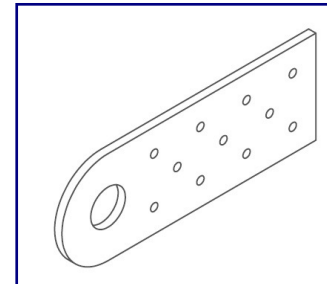

### Arbor Press

Catalog #: GT143 Quantity: 1

Use to straighten bent flanges and repair bows in the channel web. 10-Ton direct press.

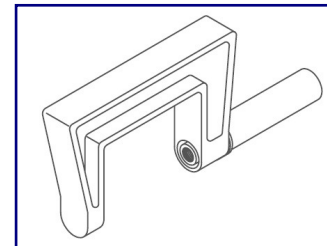

### Frame Hold-Down with Roller

Catalog #: GT110 Quantity: 2

Use when pushing up on frame in order to hold frame in the down position.

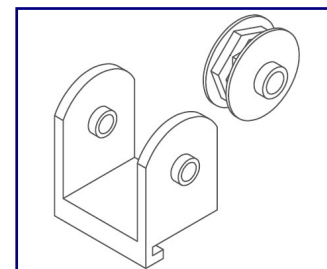

### Chain Cradle

Catalog #: GT155 Quantity: 1 each

8" (203.20 mm); 10" (254.00 mm); 12" (304.80 mm)

Protects chain from unwanted kinks and binding when wrapping around the frame. Most effective when used in repairing a 'rainbow'.

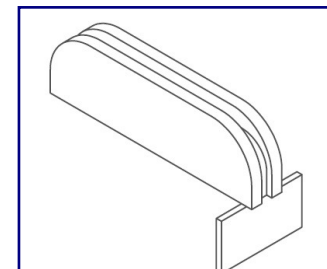

## COMPONENT INVENTORY & DESCRIPTION

### Floating Crossmember

Catalog #: GT160 Quantity: 1

Use with hydraulic and adjustable jack stands. May be positioned at any location on the treadway.

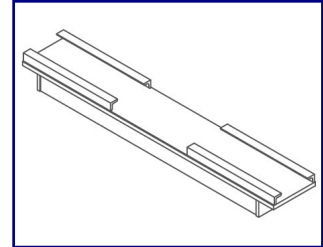

### Chain Locks

Catalog #: GT192 Quantity: (1Per Tower)  
5/8" chain (15.8 mm)

Use with all pull towers to enable continuous pulling.

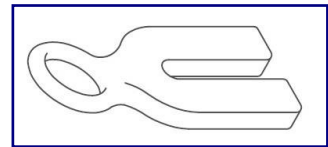

### Block Chain Anchor

Catalog #: GT194 Quantity: 2

To be used in conjunction with rail pull tool. May also be used with the power block to make multiple pulls with one tower.

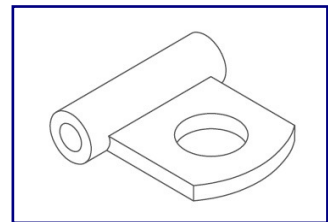

### Air/Hydraulic Pump with Hose & Gauge, 10,000 PSI

Catalog #: 1351 Quantity: 1 per Tower

Operates all pulling and finishing components. Pumps feature a large, easy to read, liquid filled pressure gauge for the precise monitoring of pull pressure.

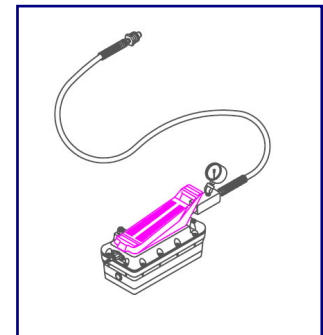

### Air/Hydraulic Pump with Hose / No Gauge

Catalog #: 1350 Quantity: 1

Used to mobilize ramps.

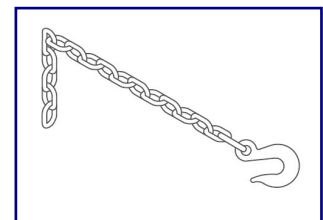

### Chains

Catalog #: 1596 Quantity: 1 per Tower  
Grade 80 5/8" x 8' (15.88 mm x 2.44m) with Grab Hook

## COMPONENT INVENTORY & DESCRIPTION

### Nylon Strap

Catalog #: GT111 Quantity: 2

2" x 36" (50.80 mm x 914.40 mm)

Used for pulling on the sheet metal structure of the cab.

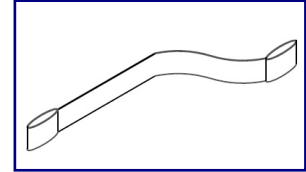

### Hydraulic Ramps

Catalog #: GF200 Quantity 2

Heavy-duty 10' ramps have hydraulically operated casters for easy mobility and may be stored away from the platform when not in use. Ramps attach to either end of the platform for drive-on/drive-off convenience.

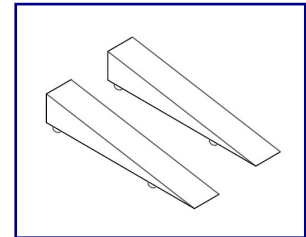

## GT3800 OPTIONAL ACCESSORIES

### Jack Stand, Height Adjustable

Catalog #: GT104 Quantity: 2

The adjustable stand has all the capabilities as the hydraulic stand except it adjusts manually. Height adjustments range from 26" – 40" (660.40 -1016.00 mm) at 1-1/2" increments.

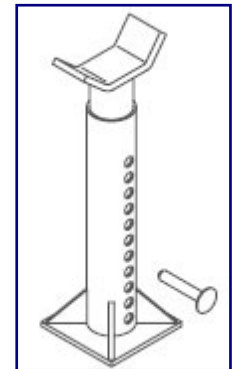

### Power Block

Catalog #: GT109 Quantity: 1

Use to make multiple pulls with one tower. Doubles the power to effectively repair extensive frame damage.

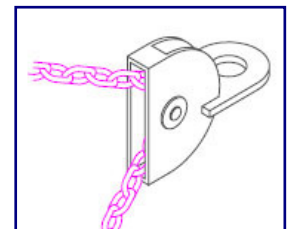

### Flange Wrench Assembly

Catalog #: GT137 Quantity: 1 each

Multi-position flange wrench allows leverage to repair bent flanges. Includes head with a 1/2" opening, head with a 3/4" opening, and 36" handle.

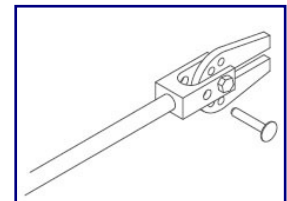

**Outer Frame Hold Down**

*Catalog #: GT144 Quantity: 1*

Use to anchor or pull lower flange or bottom of frame.

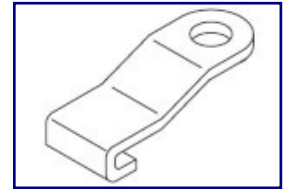

**Portable Push/Pull Tower**

*Catalog #: GT149 Quantity: 1*

Tower may be placed at any position along the treadways. Attachments allow the tower to push or pull with a 25-Ton RAM

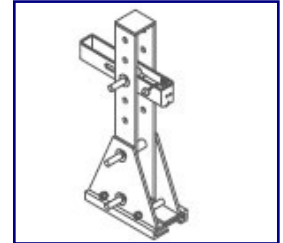

**Floating Crossmember**

*Catalog #: GT160 Quantity: 1*

Use with hydraulic and adjustable jack stands. May be positioned at any location on the treadway.

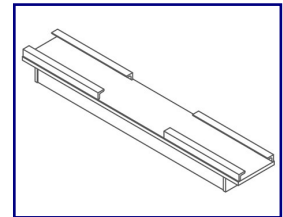

**Portable Anchoring Plate Assembly**

*Catalog #: GT158 Quantity: 1*

Use in conjunction with the heavy duty chain slack remover

